

MODULI LINEARI
LINEAR MODULES

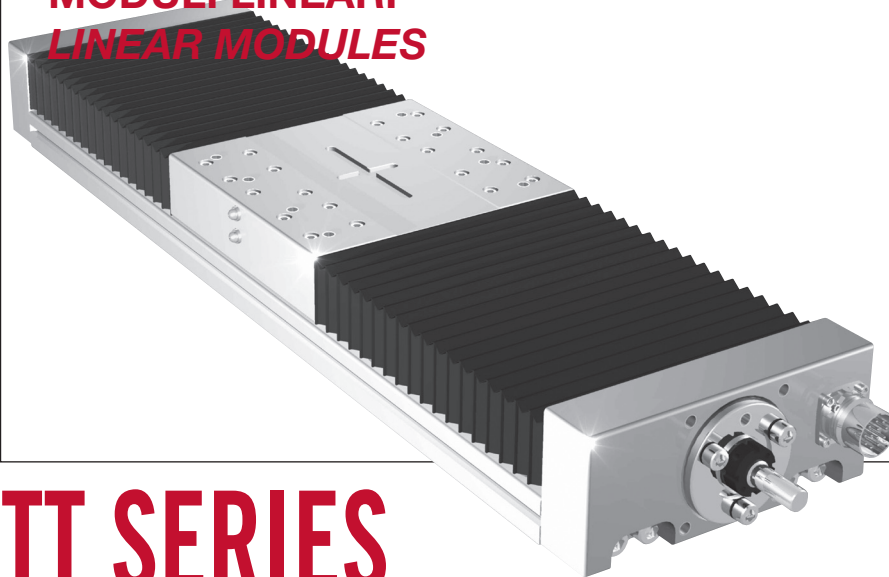

TT SERIES

Usò e manutenzione - Use and maintenance

ELMORE



Ingrassaggio - Lubrication

Inserire il beccuccio dell'erogatore negli appositi ingrassatori.

- A** - Pattini
- B** - Chiocciola

Ripetere l'operazione ogni 100 km o 6 mesi d'uso.

Insert the tip of the oil can in the specific grease nipples.

- A** - Linear block
- B** - Ball screw nut

Repeat this operation every 100 km or 6 months of use.

Tipo di lubrificante: grasso a base di sapone di Litio della classe No 2
Type of lubricant: Lithium soap grease of class No 2.

Quantità di lubrificante necessaria per la rilubrificazione dei carrelli:
Quantity of lubricant necessary for linear block re-lubrication:

TT 100	1	unità/unit: g
TT 155	2	unità/unit: g
TT 225	4	unità/unit: g
TT 310	6	unità/unit: g

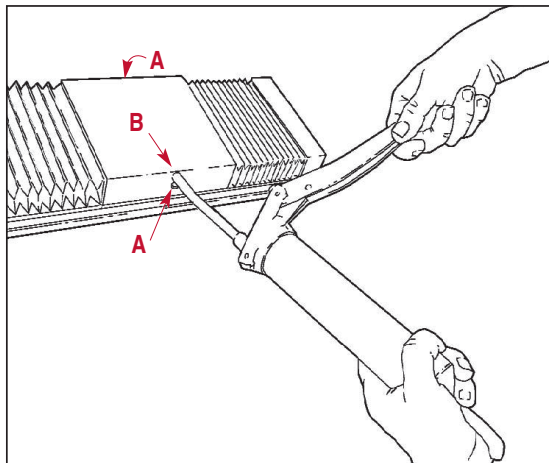

Con presenza di condizioni particolarmente stressanti (carichi elevati, impurità eccessive, etc.) richiedere ulteriori informazioni.
For specially stressed applications or difficult environmental conditions, lubrication should be carried out more frequently.





Ingrassaggio - Lubrication

Viti a ricircolo

Le chiocciolate usate per le tavole lineari **EL.MORE** serie **TT** devono essere rilubrificate ogni $50 \cdot 10^6$ giri. Quindi utilizzando la tabella di conversione seguente a seconda del passo della vite, dovranno essere rilubrificate al raggiungimento del percorso lineare (in km) indicato.

Tipo/Type	Quantità [g] per ingrassatore Quantity [g] for grease nipple
12-05	0,3
12-10	0,3
16-05	0,6
16-10	0,8
20-05	0,9
20-20	1,7
25-05	1,4
25-10	1,7
25-25	2,4
32-05	2,3
32-10	2,8
32-32	3,7

Ball screws

The ball screw nuts of **EL.MORE TT** -series linear stages must be re-lubricated every $50 \cdot 10^6$ revolutions. Therefore, using the following conversion table, according to the lead of the screw, they must be re-lubricated on reaching the linear travel (in km) indicated.

Tabella di comparazione n° giri/percorso lineare N° turn/linear path comparison table	
Giri / Turns	$50 \cdot 10^6$
Passo / Lead 5	250 km
Passo / Lead 10	500 km
Passo / Lead 20	1000 km
Passo / Lead 25	1250 km
Passo / Lead 32	1600 km



Codifica - Codification

CODE CREATOR è un programma che assiste il cliente nella configurazione delle unità lineari **EL.MORE** e nella creazione dei giusti codici per l'ordine. E' possibile accedere facilmente al programma dalla pagina web www.elmore.it selezionando il tasto "**CODE CREATOR**" e seguendo il processo autoguidato. In conclusione al procedimento di codifica è possibile mandare una richiesta d'offerta automatica ad **EL.MORE** semplicemente registrandosi nel sito.

***CODE CREATOR** is an assistant software that helps the customers to configure **EL.MORE** linear units, providing the right codes for orders. You can easily open the software going to the web page www.elmore.it and clicking on "**CODE CREATOR**" button. Following the process is also possible to send a quotation inquiry directly to **EL.MORE** after the registration on the web site.*

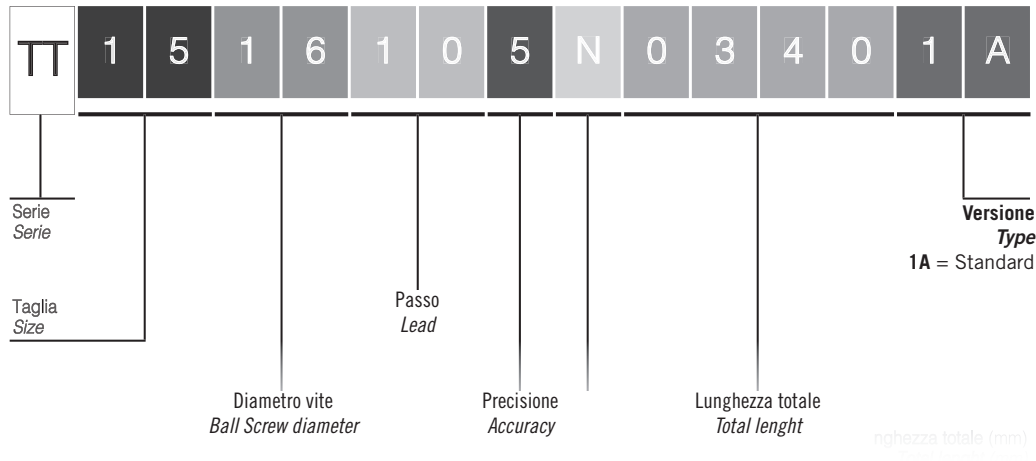



Rimozione / Sostituzione soffietto di protezione - Remove/replace protection bellows

Il soffietto è alloggiato ad incastro (tranne nella versione TT 310 nella quale viene fissato mediante velcro)

Per rimuoverlo prenderlo alle sue estremità e sollevare.

Per rimontare svolgere le stesse operazioni all'inverso.

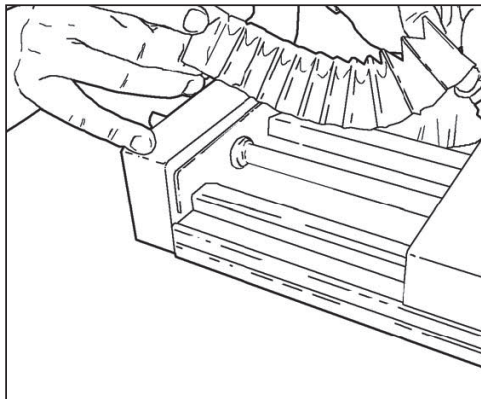

The bellow is fixed by hanging in its ends behind a metal sheet (except TT310, which is fixed by VELCRO tape).

To remove the bellow, take it at two sides at the end and lift.

Operate in the opposite way to reassemble.

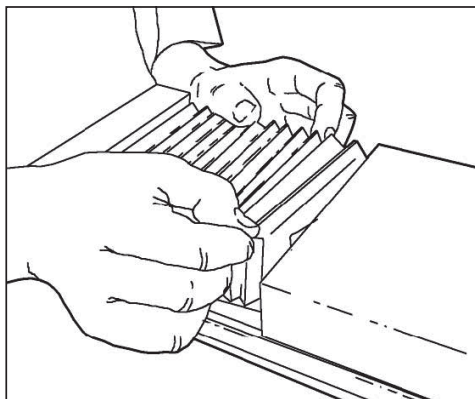

Attenzione: Non rimuovere assolutamente i piattelli lato motore e folle per non pregiudicare il corretto funzionamento della tavola
Caution: Do absolutely not remove the endplates of the linear stage, to avoid impairment of the function of the linear stage





Sostituzione proximity con connessione standard - Replacement of proximity switch with standard connection

- 1 • Rimuovere la vite di fissaggio del proximity.
- 2 • Rimuovere la piastrina passacavi all'esterno dell'unità.
- 3 • Rimuovere e sostituire il proximity avendo ben cura di ripristinare, come in origine, i collegamenti e la posizione dei cavi all'interno dell'apposita guida.
Riposizionare il dado sagomato per fissare il nuovo proximity ripristinando la posizione originaria
Rimontare la piastrina passacavi.

Dipendentemente dall'installazione è possibile che si rendano necessari il taglio e la sostituzione del cavo di collegamento al proximity o il dissaldaggio del vecchio con ricollegamento mediante saldatura del nuovo.

- 1 • *Unscrew and remove the fixing screw of the proximity switch.*
- 2 • *Remove the fixing cable plate outside of the unit.*
- 3 • *Remove and replace the proximity switch paying attention that the connections and the location of the cables in the slots are as they were in their original condition. Replace the T-nut to fix the proximity switch in its original position. Replace the fixing cable plate.*

Depending on the installation, it may be possible to cut and to replace the cable by unsoldering it and to re-solder new cables.

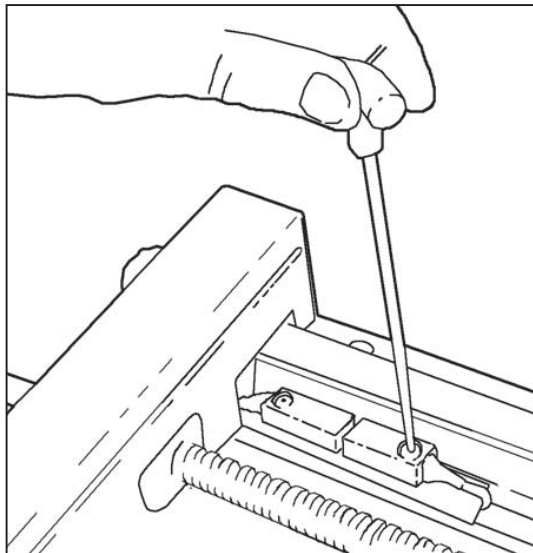

Attenzione: Non rimuovere assolutamente i piattelli lato motore e folle per non pregiudicare il corretto funzionamento della tavola





PRIMA DI INIZIARE RIMUOVERE IL SOFFIETTO DI PROTEZIONE
FIRST OF ALL REMOVE THE PROTECTION BELLOWS

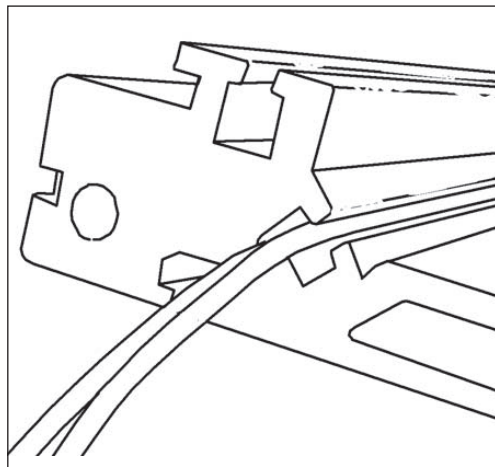
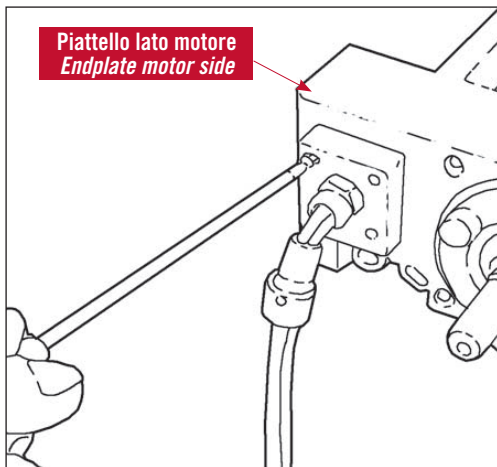

Caution: Do absolutely not remove the endplates of the linear stage, to avoid impairment of the function of the linear stage





Sostituzione proximity con connettore - Replacement of proximity switch with connector

- 4 • Rimuovere la piastrina portaconnettore all'esterno dell'unità.
- 5 • Rimuovere e sostituire il proximity avendo ben cura di ripristinare, come in origine, i collegamenti e la posizione dei cavi all'interno dell'apposita guida.
Riposizionare il dado sagomato per fissare il nuovo proximity ripristinando la posizione originaria
Rimontare la piastrina portaconnettore.

Dipendentemente dall'installazione è possibile che si rendano necessari il taglio e la sostituzione del cavo di collegamento al proximity o il dis-saldaggio del vecchio con ricollegamento mediante saldatura del nuovo.

- 4 • Remove the plate portaconnettore outside the unit.
- 5 • Remove and replace the proximity paying attention that the connections and the location of the cables in the slots are as they were in their original condition.
Replace the T-nut to fix the proximity switch in its original position.
Replace the connector plate.

Depending on the installation, it may be possible to cut and to replace the cable by unsoldering it and to re-solder new cables.

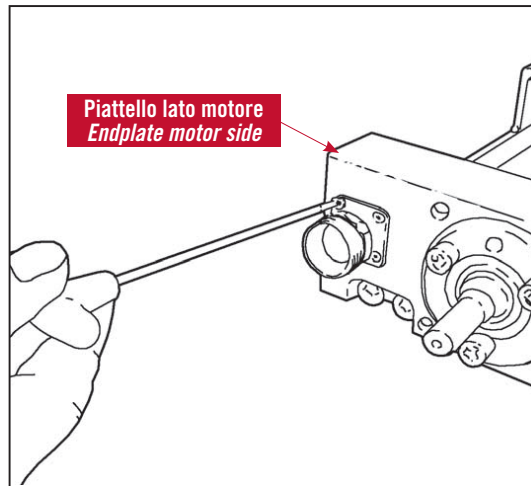

Attenzione: Non rimuovere assolutamente i piattelli lato motore e folle per non pregiudicare il corretto funzionamento della tavola





PRIMA DI INIZIARE RIMUOVERE IL SOFFIETTO DI PROTEZIONE ED EFFETTUARE L'OPERAZIONE AL PUNTO 1
FIRST OF ALL REMOVE THE PROTECTION BELLOWS AND CARRY OUT THE OPERATION INDICATED UNDER POINT 1

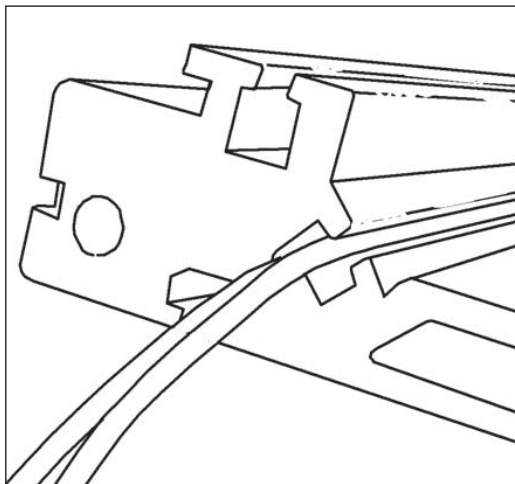

Caution: Do absolutely not remove the endplates of the linear stage, to avoid impairment of the function of the linear stage





Schemi di collegamento e posizionamento proximity-*Patterns of connection and positioning of proximity switches*

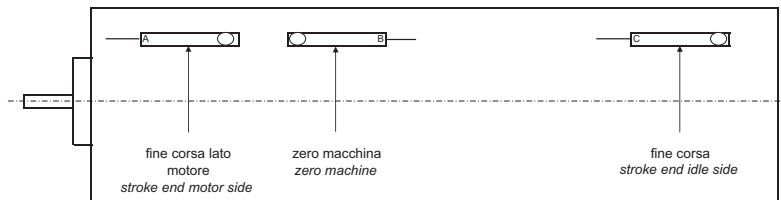

TT 155
TT 225

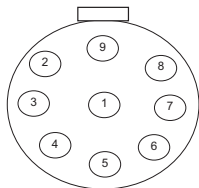

VISTA LATO
 CONNESSIONE CAVI
CONNECTION OF CABLES

Proximity A	Proximity B	Proximity C
1- BLU / BLUE	4- BLU / BLUE	7- BLU / BLUE
2- MARRONE / BROWN	5- MARRONE / BROWN	8- MARRONE / BROWN
3- NERO / BLACK	6- NERO / BLACK	9- NERO / BLACK
1-2-3 (TLW3MB1)	4-5-6 (TLW3MB1)	7-8-9 (TL WMB1)





TT 100

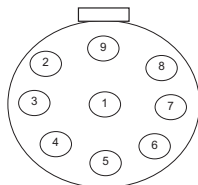
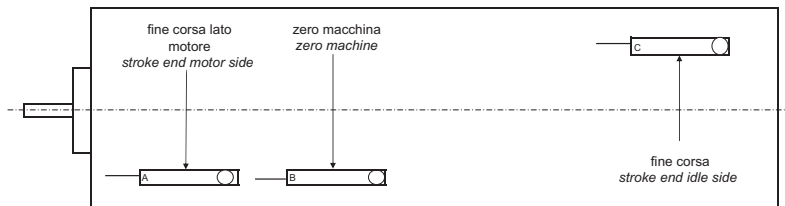

VISTA LATO
CONNESSIONE CAVI
CONNECTION OF CABLES

Proximity A	Proximity B	Proximity C
1- BLU / BLUE	4- BLU / BLUE	7- BLU / BLUE
2- MARRONE / BROWN	5- MARRONE / BROWN	8- MARRONE / BROWN
3- NERO / BLACK	6- NERO / BLACK	9- NERO / BLACK
1-2-3 (TLW3MB1)	4-5-6 (TLW3MB1)	7-8-9 (TL WMB1)



Avvertenze - Warnings



PRECAUZIONE NELL'INSTALLAZIONE E NEGLI SPOSTAMENTI. ATTREZZATURA DI PESO NOTEVOLE.
PRECAUTIONS TO BE TAKEN WHEN INSTALLING OR MOVING. HEAVY EQUIPMENT.



NON SOVRACCARICARE. NON SOTTOPORRE A SOLLECITAZIONI DI TORSIONE.
DO NOT OVERLOAD. AVOID TORSIONAL STRESS.



NON LASCIARE ESPOSTO AGLI AGENTI ATMOSFERICI.
AVOID EXPOSURE TO ATMOSPHERE AGENTS.



PRIMA DI MONTARE IL MOTORE SUL RIDUTTORE SI CONSIGLIA DI ESEGUIRE UN PRECOLLAUDO DEL MOTORE STESSO SENZA COLLEGAMENTO AL RIDUTTORE.
BEFORE ASSEMBLING THE MOTOR ON THE REDUCTION UNIT, IT IS ADVISABLE TO PRE-TEST THE MOTOR WITHOUT CONNECTING THIS TO THE REDUCTION UNIT.



EVITARE DANNEGGIAMENTI. NON INTERVENIRE CON ATTREZZI INADEGUATI.
AVOID DAMAGE. ALWAYS USE APPROPRIATE TOOLS.



ATTENZIONE ALLE PARTI IN MOVIMENTO. NON APPOGGIARE OGGETTI SULL'ASSE.
PAY ATTENTION TO MOVING PARTS. DO NOT REST OBJECTS ON THE AXIS.



INSTALLAZIONI SPECIALI: VERIFICARE LA PROFONDITÀ DELLE FILETTATURE SULLE PARTI IN MOVIMENTO.
SPECIAL INSTALLATIONS: CHECK DEPTH OF THREADS ON MOVING PARTS.

PER ULTERIORI INFORMAZIONI SULLE CARATTERISTICHE TECNICHE FARE RIFERIMENTO AI NOSTRI STAMPATI SPECIFICI.
FOR FURTHER INFORMATION REGARDING TECHNICAL CHARACTERISTICS, REFER TO OUR SPECIFIC DOCUMENTATION.

La società **EL.MORE** non si assume responsabilità per danni in seguito ad errata interpretazione delle stesse. La società **EL.MORE** si riserva il diritto di modificare i propri prodotti in base alle esigenze di miglioramento tecnico degli stessi.

*The **EL.MORE** Company shall not be held responsible for damages resulting from incorrect interpretation of the same. The **EL.MORE** company reserves the right to modify its products according to technical improvement requirements.*

**ELMORE**
Engineering

EL.MORE s.r.l. - Via Concordia, 5/C4 (Lotto Verde) - I-20099 Sesto San Giovanni (MI)
Tel. +39 02.241215.1 - Fax +39 02.24414980 - www.elmore.it - e-mail: info@elmore.it

EL.MORE GmbH - Seidenweberstr, 10 - D-41189 Monchengladbach
Tel. +49 2166 6218456 - Fax +49 2166 854007 - www.elmore.de - e-mail: info@elmore.de